

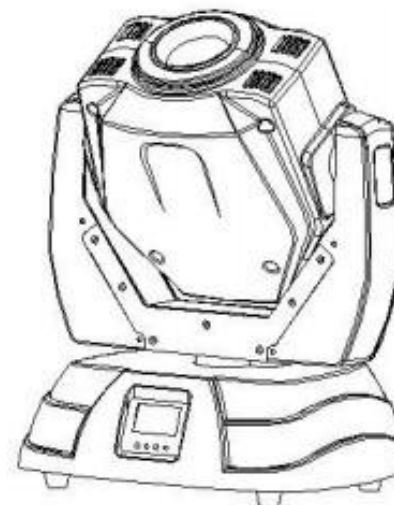

CE

LED Moving Head spot light



User manual

1. Before using

1. Dispacking
2. Instruction
3. Attentions

2. Installation

1. Fixed installation
2. Connection of the master machine
3. The connection of the DMX 512

3. Specification

1. Skill specification
2. luxmeter
3. View of the light

4. Supplement

1. Set of the display
2. control channal
3. supplement
4. picture of structure

4.4 picture of structure

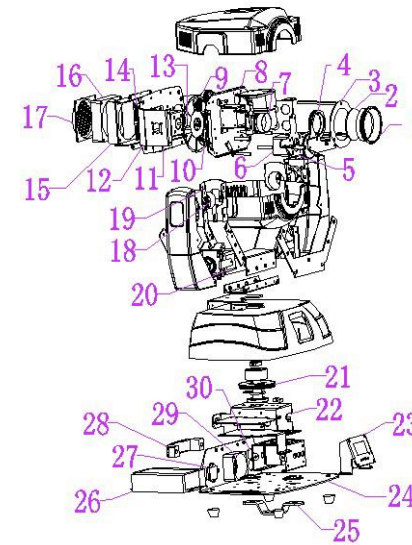

number	name	number	name	number	name
1	Sheath of lens	11	Drive-board of motor	21	Component of the X axis driven wheel
2	concave-convex lens	12	Main stand of head	22	Stand of the bridge
3	Fix board	13	White LED component	23	Component of the screen
4	Prism board	14	The heatout sheet of the LED	24	Base board
5	Fix board of lens	15	Stand of the lens motor	25	Stand of the hook
6	stepper motor	16	Plastic motor	26	power
7	Component of gocus	17	Sheath of motor	27	Plug of the power
8	Stand of Gobo motor	18	y axis driving wheel	28	knob
9	Gobo sheet	19	Strengthen board	29	Plastic motor
10	Color sheet	20	stepper motor	30	Three pin XLR

4.3 supplement

Failure	Failure Analysis	Failure Parts
Whole light doesn't Work	Power supply loose or fault	power line
		fuse
		power supply
Beads aren't lighted	LED13 beads damaged	LED13 bead board
	Driven Plate damaged	Driven Plate
	XH2 core cables loose contact or disconnect	XH2 core cables
Fan works unnormal	Lamp's fan damaged	Plastic moter
	Bottom's fan damaged	Led driven board
		Plastic moter
		power switch
the whole can reset but can not be controlled	Display damage	display
	XH3 pin does not connect well	XH3 pin connect
	Do not operate follow the	instruction
the mistake of the three-prism	LED control board	Three-prism fall of
the mistake of the color sheet		Three-prism moter
		Color sheet moter
the mistake of the rotate Gobo light		Rotate Gobo moter
		Rotage Gobo iam
		Gobo hall board
		Gobe moter damage
		Vertical moter damage
		Vertical belt damage
the mistake of the vertical work		Vertical hall board
		optical code board
		Horizontal moter
the mistake of the horizontal work		horizontal belt damage
		horizontal hall board
	optical code board	

1.1 DISPACKING

Thank you for using the products of our CO..For your owe safety,please read this manual before installing the device.This manual covers the important imformation of installing and using.Please install and operate following the manual book.Meanwhile ,please keep this manual well for using at any time.

Our moving wash is made of a new type of high temperature strength of engineering plastics and cast aluminum casing from manufacturing,design beautiful smooth,fully embodies the characteristics of modern lighting products.Products according to strict CE standards of production design,in full compliance with international standards DMX512 prorocol,a single control can also be controlled in conjuction with each other,suitable for large-scale performances,theater,studio and places of higher Disco use.

The Moving head light adopt the powerfull LED lamp which is import in the foreign country. Once receive it,please handle it carefully and check if there is some shatter because of transportation and the following fittings are ok:

main light:-----one

singal cable-----one

stand----- one

Manual-----one

1.2 INSTRUCTIONS

- The machine is moving head light used to make the decorate effect.
- Don't start the machine when it's temperature changed drastically,because the change of the temperature may damang the machine,start it when temperature is in the common condition.
- Be carefully for the shock when install
- Don't pull up the machine by the heda of it,this may damage it,use the special tools to transport it.
- The install place shout not overheating overdamp or too much dust,don't put wire on the ground to avoid hurting any man,
- At the botton of this product there is a hole for safety wire,please make sure that the safety wire is done with it.
- When the machine is not installed or the screw is not tighten,don't start it.
- Caution:when lens is damaged visible,change to keep the previous effect.
- It maybe injure the machine if it is controlled by the guy who is not professional,lots of the damage is coming by this.
- Use the original packing when delivery it. Forbit change the machine unless approved.
- The fault is not belong to guarantee to keep in good repair,if you don't control it under the instrution.The short circuit,damage, accidental contact,the damage by ultraviolet radiation,the blow up,all of this not belong to guarantee to keep in good repair.

4.2 The Channel

	channal instruction	data	effect
1	Open Strobe	000~255	the strobe, from low speed to
2	Dimmer	000~255	from bright to dark
3	GOBO plate	000~009 010~019 020~029 030~039 040~049 050~059 060~069 070~079 080~089	blank Gobo 1 Gobo 2 Gobo 3 Gobo 4 Gobo 5 Gobo 6 Gobo 7 Gobo 8
4	GOBO Rotate	000~128 129~133 134~170 171~175 176~213 214~219 220~255	GOBO angle empty GOBO rotate positive-going empty GOBO rotate opposite-going empty rotate outward and homeward
5	scan horizontal	000~255	0~540 rotate
6	Scan vertical	000~255	0~270 rotate
7	color sheet	000~009 010~019 020~029 030~039 040~049 050~059 060~069 070~079 080~089 090~099 100~109 110~119 120~129 130~139 140~149 150~159 160~169 170~179 180~255	white half color 1 color 1 half color 2 color 2 half color3 color 3 half color 4 color4 half color 5 color 5 half color 6 color 6 half color 7 color 7 half color 8 color 8 half color9 rainbow effect ,from slow to fast
8	Focus	000~255	unlimited focus
9	prism	000~127 128~255	No prism Three prism
10	prism rotate	000~255	prism rotate
11	speed of horizontal or vertical	000~255	speed max to min speed

4.1 Set of the display

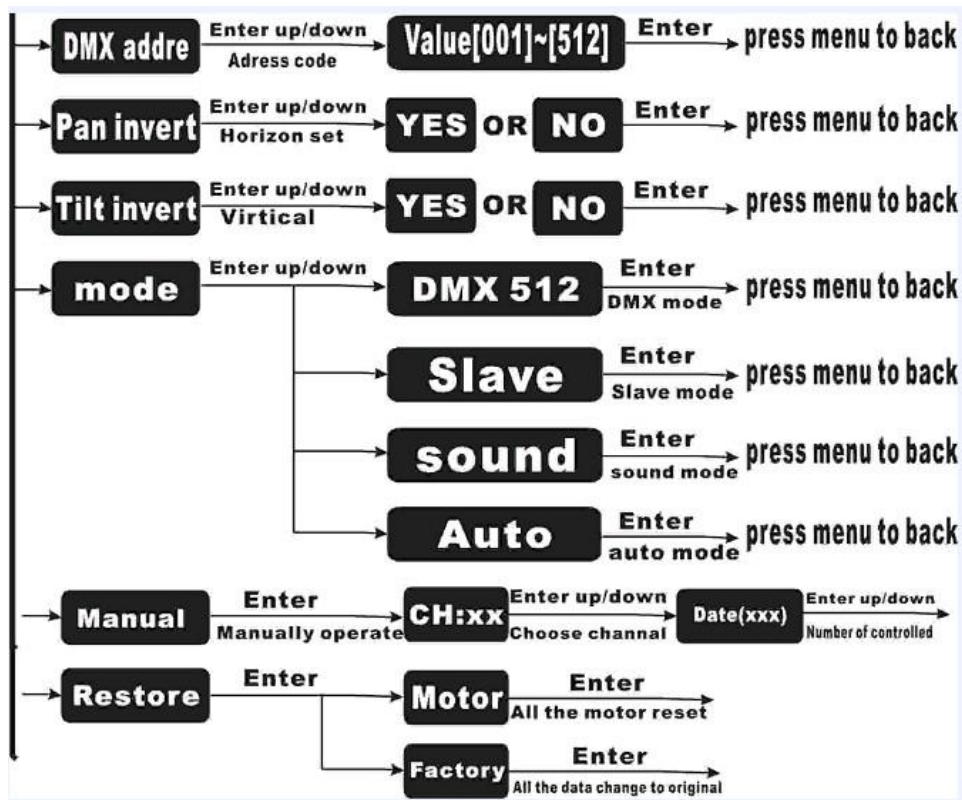

1.3 Attention

The guy who install it and maintain it,you must follow:

-Have the qualification of technician.

-Follow the instruction

Attention:

-prevent water damp,cut the power off when open the machine. Keep Clear-High Voltage,the machine is in good condition before sell.To confirm the safety,please control it under the instruction.The factory will not take responsibility,if you don't control it under the instruction or change the machine personally or change the instruction casually.

-Don't conect te power wire with other wire,confirm the power is availerbale to the machine,expecially don't outstrip the power.

-confirm plug connect with the power, and the switch button is off before you connect with power.

-Confirm the power wire is not puckered or damaged by the sharp,check it once in a while. -Cut the power when it is not work or maintained.When you cut off power,pull up the plug not the wire to avoid the damage.

-The level of protection is the first level,connect the green/yellow to the ground.The connection and maintainment shoud be dong by the careerman.

-Don't connect the machine to the dimmmer equipment.

-Don't make on and off action frequently,or the working life will become short.

-It may be smeelly when the first use,it's the common.

-when the light is off just now,the light is hot,wait for 15 minute3

-The workplace temperature must less than 45°

-Keep 0.5meter between the inflammable obj

- To avoid hurting the eyes,please do not look at the lamp-house steadily.Especially for the eye sicker

2.1 Install The Equipment

-During installation, please make sure no inflammable thing within 0.5 meters.

WARNING: use the two hooks to fix the bottom of the machine, and be sure the place where you installed is safe, and it can stand ten times weight than the light, test that if the place is out of shape in one our.

-You'd better add second protection to avoid the shed of lose of the spare parts.

the light can be installed on the shelf. as shown in illustration

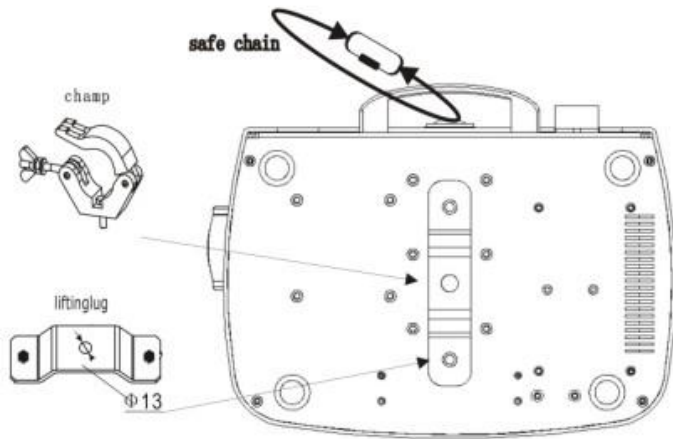

The strand wire is usually used in the shelf for the safety, the strand wire should stand ten times weight than the machine. you should use the stand wire which has safety lock pins, the strand wire pass through the hole at the bottom, then tie it to the fixity, then tighten it.

3.3 View of the light

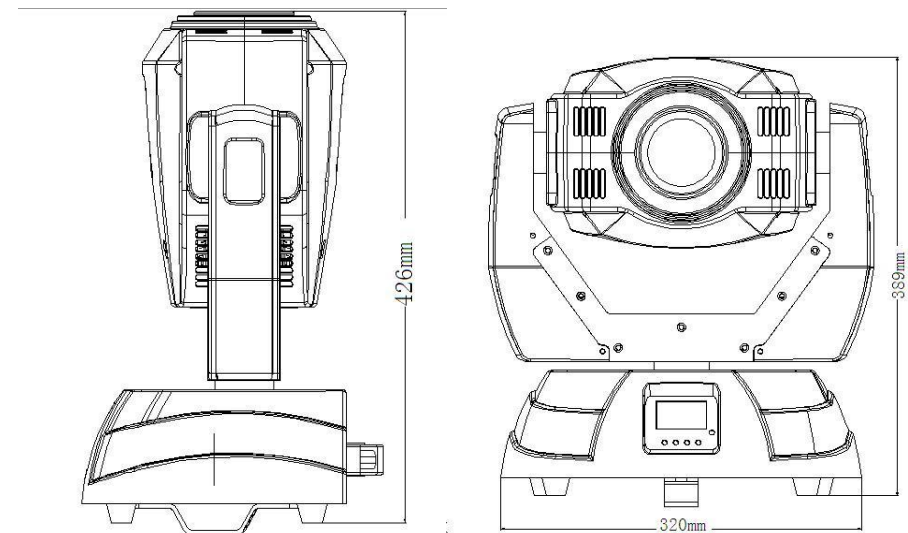

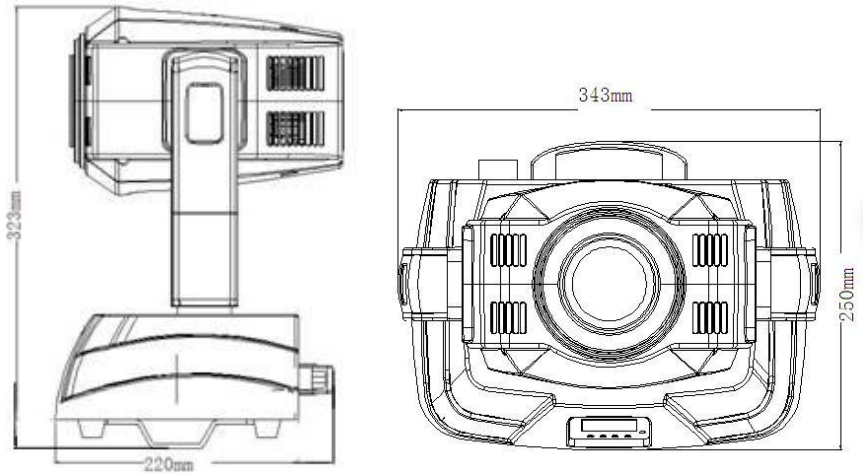

9

3.2 luxmeter

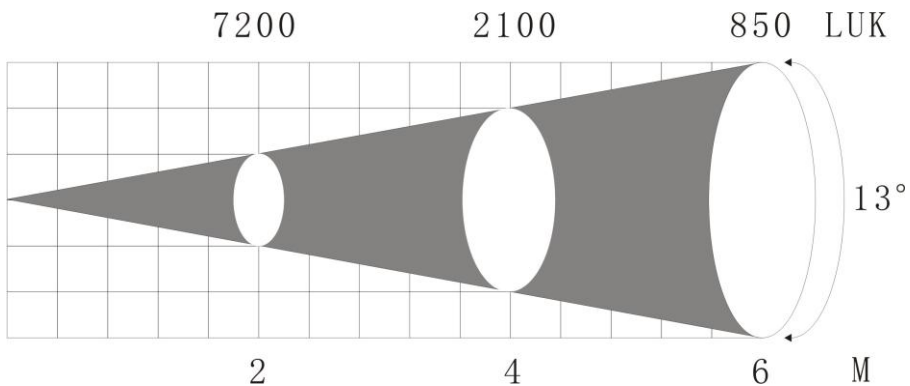

8

2.2 The Connect of Main Frame

- Confirm the power before connect!
- use the plug to connect the machine to the power.

(European Union)wire	(United states)wire	Line	Mark
Brown	Black	live line	L
light blue	White	null line	N
yellow/green	green	earth wire	

The connect of DMX-512 and lights.

Connect the XLR-XLR control wire from DMX Pulse Output of the controller to the light,

XLR connection: DMX output
XLR plug seat



1. earth wire 2. cathode 3. anode



DMX

plug 1. earth wire 2. cathode 3. anode Attention: The last DMX signal wire must connect to the loop plug seat via a electric resistance

2.3 The connection of the DMX 512/the lights

◆Connect the XLR-XLR control wire from output of the controller to the input of the light,and connect the output of the master light to the slave light,and the like,till connect all the light,the end connect the loop plug to the output of the last one.Pls don't connect more than 32pcs light.

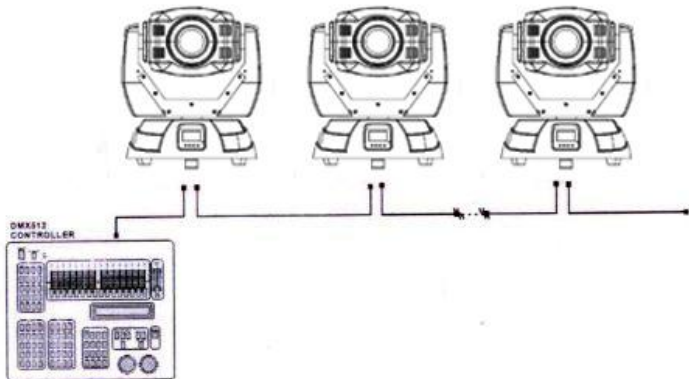

3.1 SKILL SPECIFICATION

Power source:

- 1.Voltage AC 100-240V, 50/60HZ
2. Total power: 150W
- 3.LED Lamp: 1PCS (60 W white)
- 4.Cooling system: Built-in convection of heat- cold stream
- 5.Control channal:12CH
6. Color wheel:8color+white,rainbow effect can be speed
7. pattern:8 figure+white,may be speed,running water and the pattern jitter effects,positive and negative rotation function
8. Prism:rotating speed,direction variable
9. Focus:2m to the infinite power adjustmeng
10. Beam angle:13°
11. Dimmer strobe:0-100% linear dimmer,1-20times/sec,high-speed electronic srobe effects
12. Rotation angle:horizontal(x-axis)0-540with automatic error correction,16bit adjustment.The vertical 0-270 without automatic error correction,16bit adjust
13. The rotation speed:0-270 with automatic error correction,16bit adjust