

# 30W SPOT MOVING HEAD

## USER MANUAL



### Snapshot

Use on Dimmer	⊘
Outdoor Use	⊘
Sound Activated	✓
DMX	✓
Master/Slave	✓
100 V / 240 V Voltage Selection Switch	✓
Replaceable Fuse	✓
User Serviceable	⊘
Duty Cycle	⊘

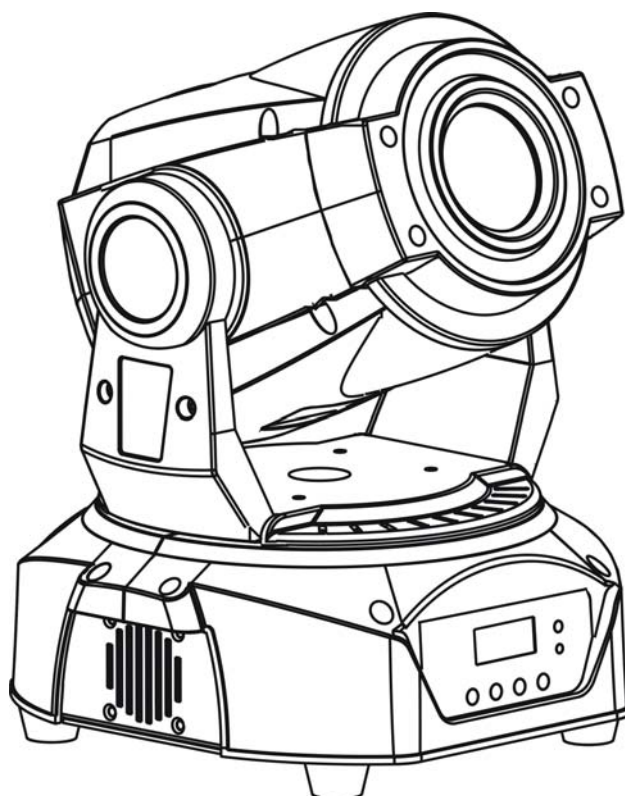

# TABLE OF CONTENTS

1. BEFORE YOU BEGIN	3
WHAT IS INCLUDED	3
UNPACKING INSTRUCTIONS	3
MANUAL CONVENTIONS	3
ICONS	3
SAFETY INSTRUCTIONS	4
2. INTRODUCTION	5
FEATURES	5
PHOTOMETRICS	5
PRODUCT DIMENSIONS	6
PRODUCT OVERVIEW	7
3. SETUP	8
AC POWER	8
POWER LINKING	8
SIGNAL LINKING (DMX)	9
FUSE REPLACEMENT	9
MOUNTING	9
ORIENTATION	10
RIGGING	10
4. OPERATING INSTRUCTIONS	11
CONFIGURING THE STARTING ADDRESS	11
CONTROL PANEL FUNCTIONS	11
MENU MAP	12
DMX OPERATION	13
STANDALONE OPERATION	13
AUTOMATIC FAST	13
AUTOMATIC SLOW	13
SOUND-ACTIVE	13
CHANNEL	13
DEGREE	14
REVERSAL	14
RESET	14
LOAD DATA	14
MASTER/SLAVE	15
DMX CHANNEL VALUES	16
5. APPENDIX	18
DMX PRIMER	18
GENERAL MAINTENANCE	18
FIXTURE LINKING	19
DATA CABLING	19
DMX DATA CABLE	19
CABLE CONNECTORS	19
3-PIN TO 5-PIN CONVERSION CHART	20
SETTING UP A DMX SERIAL DATA LINK	20
SETTING THE STARTING ADDRESS	20
GENERAL TROUBLESHOOTING	21
TECHNICAL SPECIFICATIONS	22

# 1. BEFORE YOU BEGIN

## What is included

- 1 x Spot
- 1 x Mounting bracket and screws
- 1 x Power cable
- 1 x User Manual

## Unpacking Instructions

Immediately upon receiving a fixture, carefully unpack the carton, check the contents to ensure that all parts are present, and have been received in good condition. Notify the shipper immediately and retain packing material for inspection if any parts appear damaged from shipping or the carton itself shows signs of mishandling. Save the carton and all packing materials. In the event that a fixture must be returned to the factory, it is important that the fixture be returned in the original factory box and packing.



## Manual Conventions

manuals use the following conventions to differentiate certain types of information from the regular text.

CONVENTION	MEANING
[10]	. A LCD Display to be configured
<Menu>	. A key to be pressed on the fixture's control panel
1~512	. A range of values
50/60	. A set of values of which only one can be chosen
<i>Settings</i>	. A menu option not to be modified (for example, showing the operating mode/current status)
<i>MENU &gt; Settings</i>	. A sequence of menu options to be followed
ON	. A value to be entered or selected

## Icons

This manual uses the following icons to indicate information that requires special attention on the part of the user.

ICONS	MEANING
	. This paragraph contains critical installation, configuration or operation information. Failure to comply with this information may render the fixture partially or completely inoperative, cause damage to the fixture or cause harm to the user.
	. This paragraph contains important installation or configuration information. Failure to comply with this information may prevent the fixture from functioning correctly.
	This paragraph reminds you of useful, although not critical, information

## Safety Instructions



Please read these instructions carefully. It includes important information about the installation, usage and maintenance of this product.

- Please keep this User Manual for future consultation. If you sell the unit to another user, be sure that they also receive this instruction booklet.
- Always make sure that you are connecting to the proper voltage, and that the line voltage you are connecting to is not higher than that stated on the decal or rear panel of the fixture.
- This product is intended for indoor use only! To prevent risk of fire or shock, do not expose fixture to rain or moisture.
- Make sure there are no flammable materials close to the unit while operating.
- The unit must be installed in a location with adequate ventilation, at least 20 in (50 cm) from adjacent surfaces. Be sure that no ventilation slots are blocked.
- Always disconnect from power source before servicing or replacing fuse and be sure to replace with same fuse source.
- Secure fixture to fastening device using a safety chain.
- Maximum ambient temperature (Ta) is 104° F (40° C). Do not operate fixture at temperatures higher than this.
- In the event of a serious operating problem, stop using the unit immediately. Never try to repair the unit by yourself. Repairs carried out by unskilled people can lead to damage or malfunction. Please contact the nearest authorized technical assistance center.
- Never connect the device to a dimmer pack.
- Make sure the power cord is never crimped or damaged.
- Never disconnect the power cord by pulling or tugging on the cord.
- Never carry the fixture directly from the cord. Always use the hanging/mounting bracket.
- Avoid direct eye exposure to the light source while it is on.
- Never carry the fixture by holding the head. Always use the carrying handle.

## 2. INTRODUCTION

### Features

- 10 or 15-channel and 10 or 13-channel DMX moving yoke
- Pan : 540° / tilt: 270°
- Color wheel
  - 7 colors + white
  - Rainbow effect
- Gobo Wheel 1:(10 or 13-channel not include this Gobo wheel)
  - 8 static gobo+open+rainbow effect
- Gobo Wheel 2:
  - 6 gobo + open, 5 metal,1 glass installed
  - Rainbow effect+Gobo shake
- 3-facet prism(10 or 13-channel not include 3-facet prism)
- Variable electronic shutter (for strobing)
- Variable motorized focus
- Variable electronic dimmer (0 – 100%)
- Remote fixture reset & vector speed channel
- Individual reset of pan/tilt, color, gobo, prism, focus
- Move-in-black for pan/tilt, color, gobo
- Built-in movement macros via DMX (automated and sound)

### Additional Features

- Built-in automated programs via master/slave
- Built-in sound-active programs via master/slave
- High-power, 30 W, White LED
- User-selectable pan/tilt ranges
  - Pan: 540 , 360 , 180
  - Tilt: 270 , 180 , 90
- Automatic pan & tilt correction
- User-selectable basic or advanced operating modes
- Additional power output: max 4 units

### Photometrics

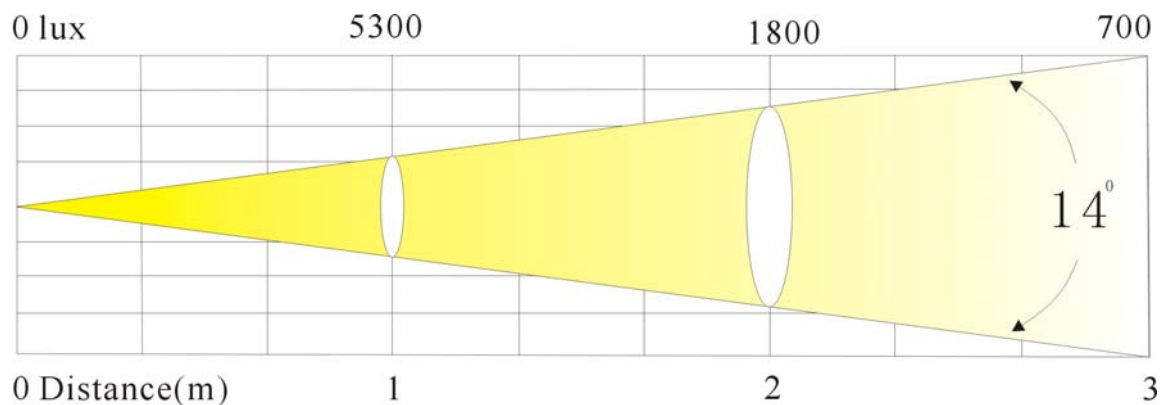

## Product Dimensions

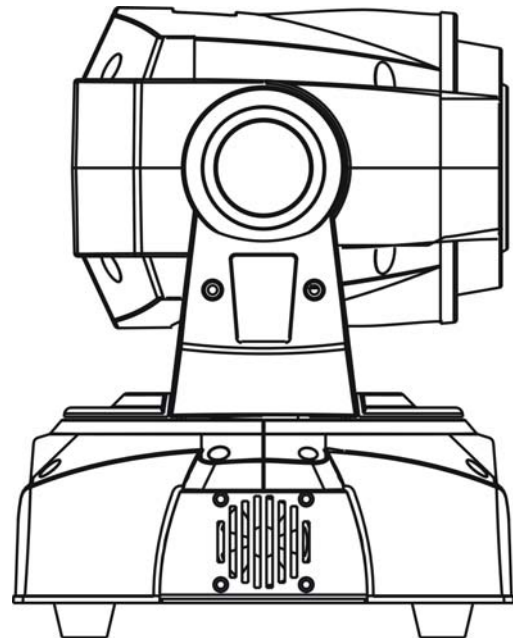
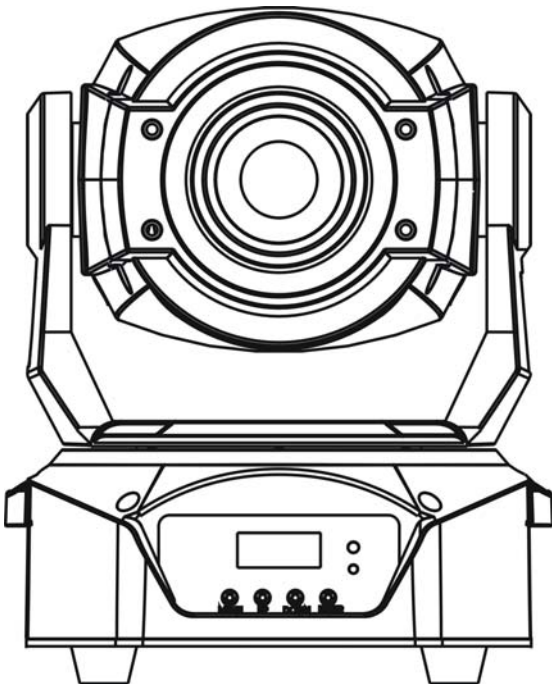
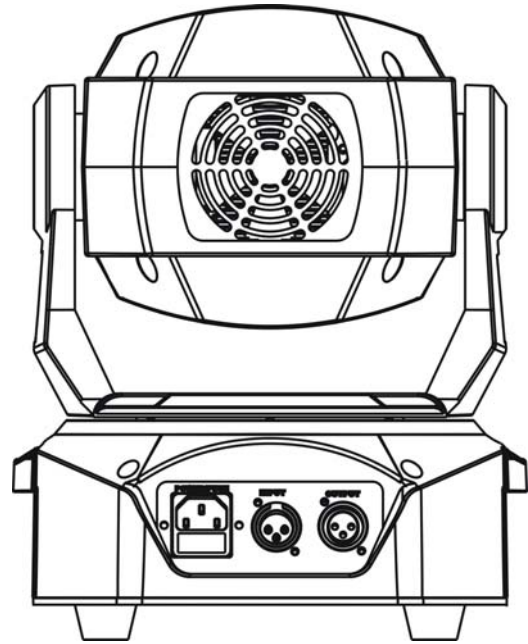
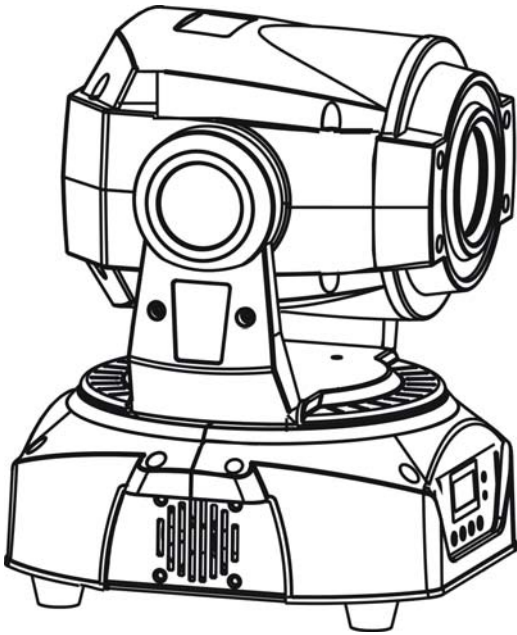

## Product Overview

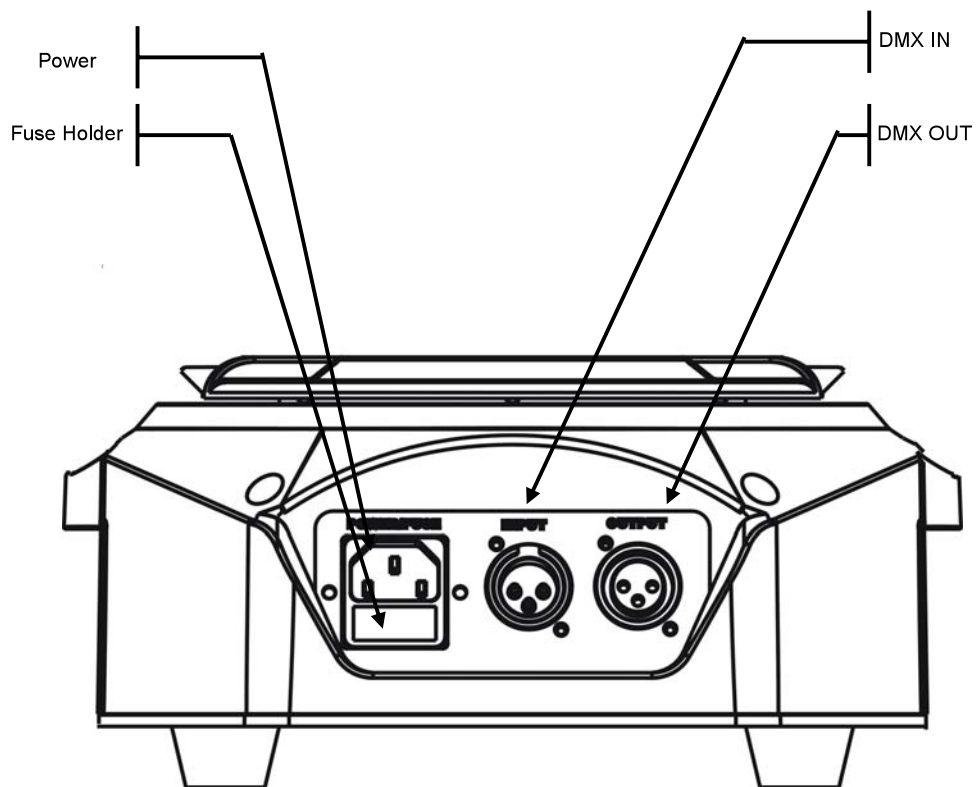
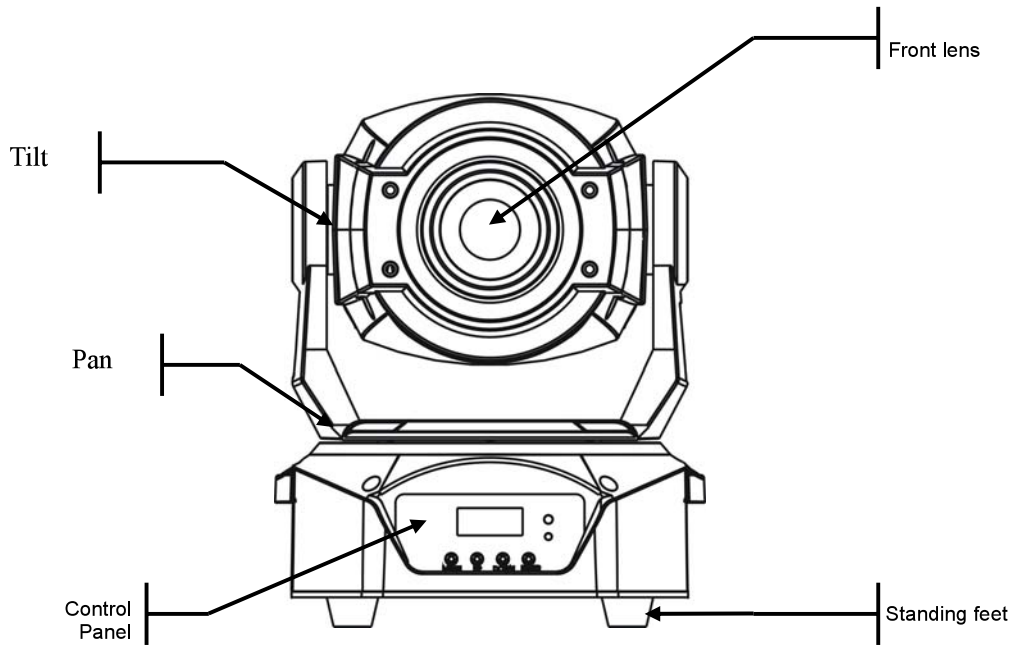

# 3. SETUP

## AC Power

This fixture runs on 100-240 VAC, 50/60 Hz. And this fixture used switch power supply, it can transform by itself when user input the power.



*Always connect the fixture to a switched circuit. Never connect the fixture to a rheostat (variable resistor) or dimmer circuit, even if the rheostat or dimmer channel is used only as a 0 to 100% switch.*

*Always connect the fixture to a circuit with a suitable electrical ground.*



The maximum quantity of fixtures that may be linked is 4.

## Power Linking

This fixture contains power linking via the edison outlet located in front of the power input cable. Please see the diagram below for further explanation.

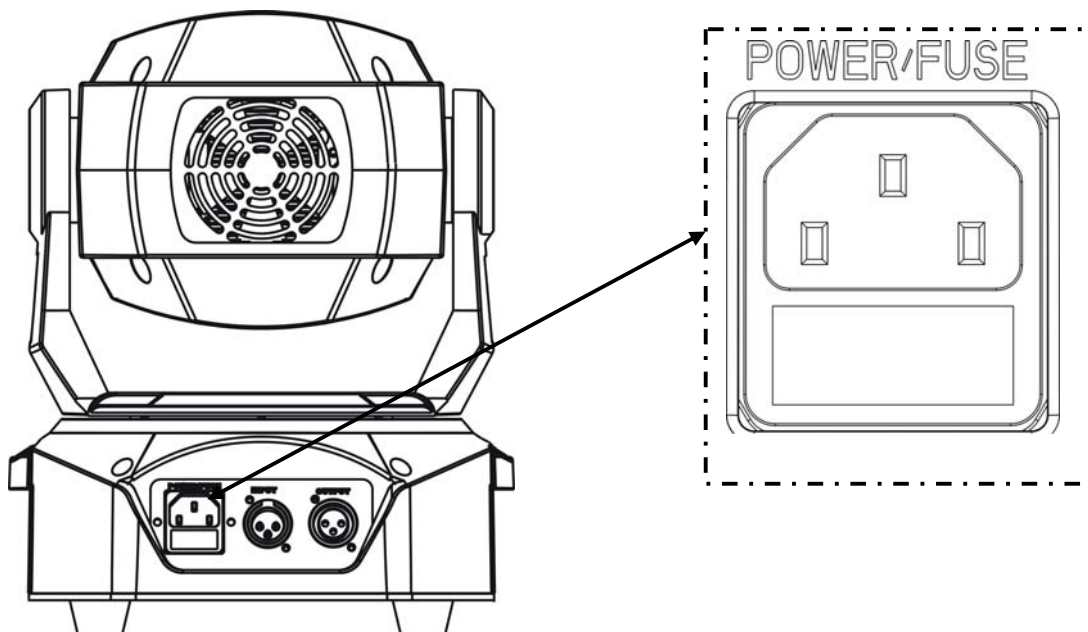



## Signal Linking (DMX)

The diagrams below illustrate the signal (DMX) linking for this fixture. This is used both in DMX mode and when operating the fixtures in Master/Slave mode. Please see the diagram below for further explanation.

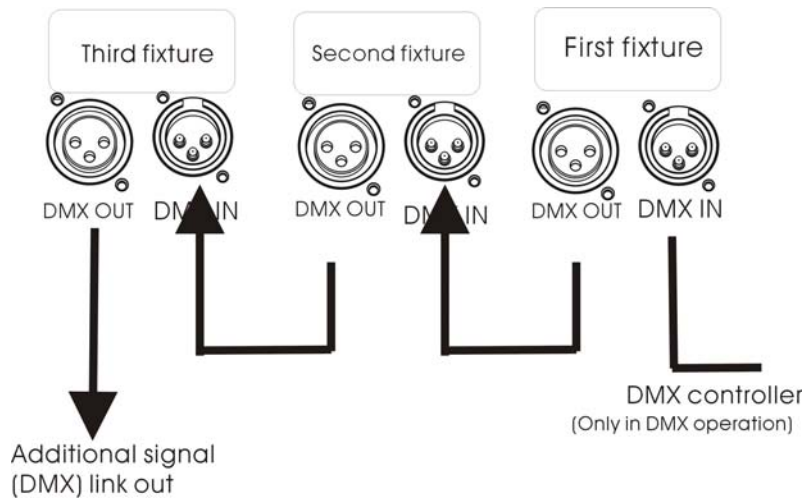
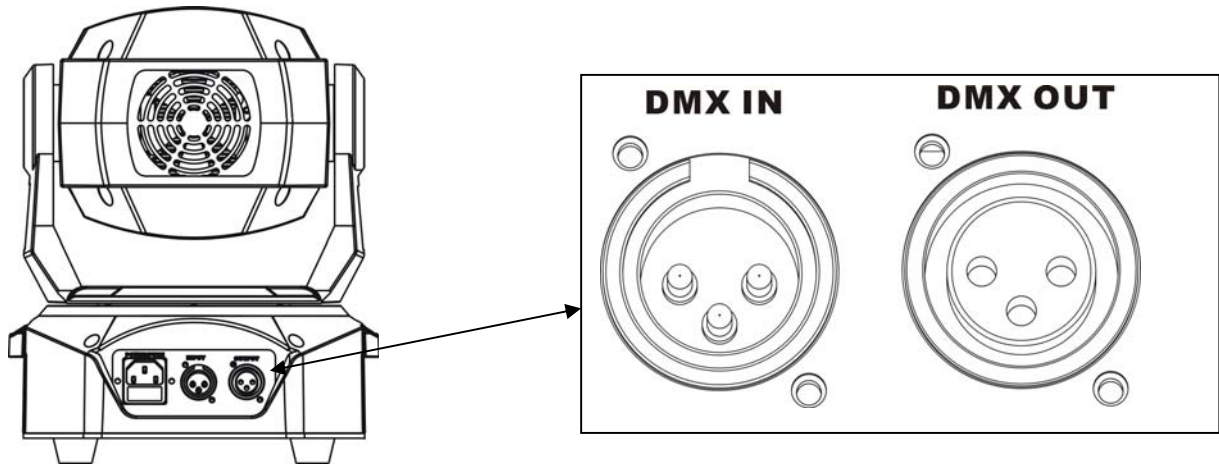

## Fuse Replacement



Disconnect the power cord before replacing a fuse and always replace with the same type fuse.



With a flat head screwdriver unscrew the fuse holder out of its housing, turning counter-clockwise. Remove the damaged fuse from its holder and replace with exact same type fuse. Insert the fuse holder back in its place and reconnect power.

The fuse is located inside this fuseholder.

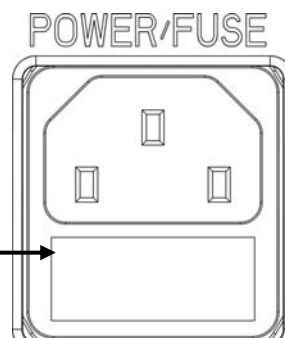

# Mounting

## Orientation

The Spot may be mounted in any safe position provided there is adequate room for ventilation.

## Rigging

Be sure that the structure can support 10 times the weight of the fixture. Please see the "Technical Specifications" section of this manual for a detailed weight listing. Mount the fixture securely. Two hanging clamps for truss mounting may be used, or nuts and bolts for permanent installation may be used. The holes in each bracket are 13 mm in size. When rigging, consider routine maintenance and control panel access. Please see the following steps for installation.

- If the power link out is intended to be used with multiple fixture, take into account the length of each power cable, and mount the fixtures close enough to one another to accommodate for this.
- Attach both included bolts in the locations indicated below, using a metric 8 mm Allen wrench.
- Attached 2 hanging clamps to the bracket in each of the two locations indicated below
- Safety cables must always be used.



Do NOT mount this fixture sideways!

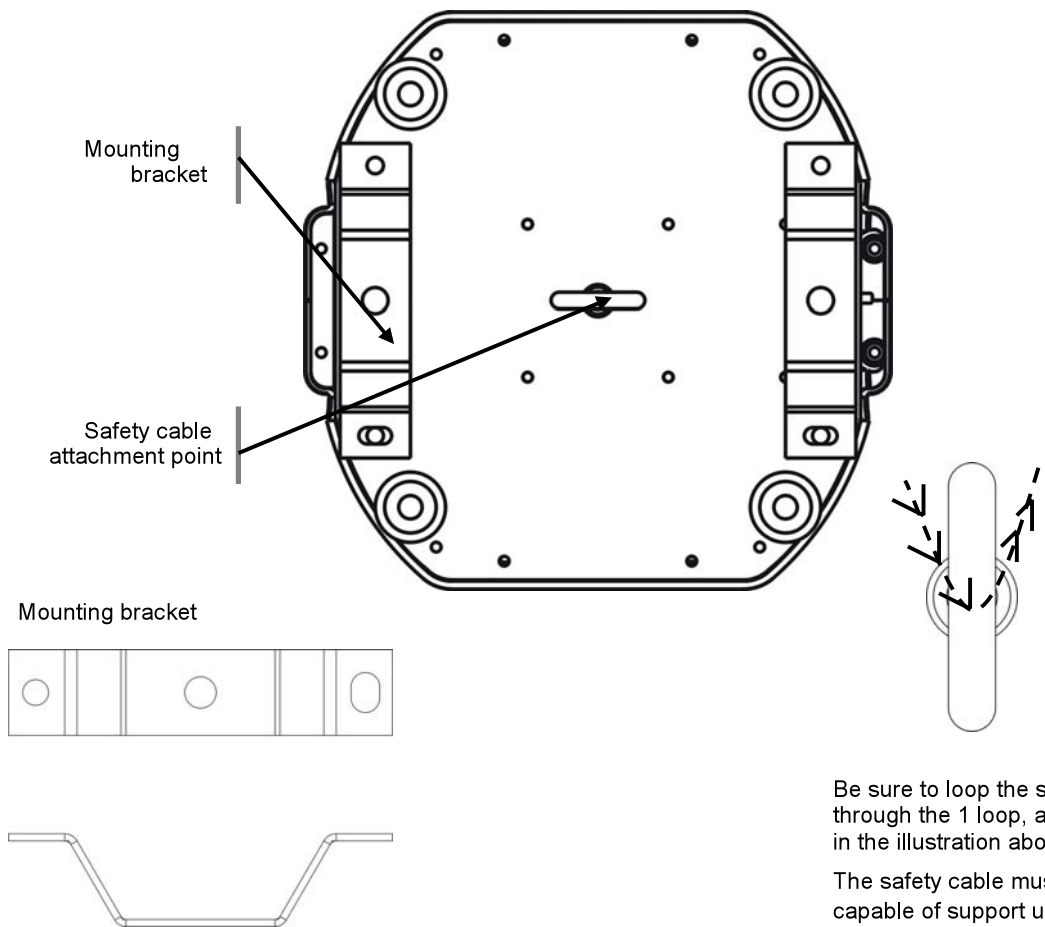

Be sure to loop the safety cable through the 1 loop, as shown in the illustration above.

The safety cable must be capable of support up to 10 times the weight of the fixture.

# 4. OPERATING INSTRUCTIONS

## Configuring the Starting Address

Each fixture requires a starting address from 1~512. A fixture requiring one or more channels for control begins to read the data on the channel indicated by the starting address. For example, a fixture that uses seven DMX channels and is addressed to start on DMX channel 100, will read data from channels: 100, 101, 102, 103, 104, 105 and 106. Choose the starting addresses for each fixture so that the channels used do not overlap. In addition, you should note the starting address selected for future reference.

The Spot fixture uses eleven or sixteen DMX channels. If this is your first time using DMX, we recommend reading the "DMX Primer" section in the "Appendix".

## Control Panel Functions

Access control panel functions using the four buttons located directly underneath the LED display on the included wired remote.

BUTTON	FUNCTION
<MENU>	Used to scroll through the current operating mode, as well as back out of the current menu option
<DOWN>	Used to select decreasing advancement in the value
<UP>	Used to select increasing advancement in the value
<ENTER>	Used to select a value and store it to memory



The Control Panel shows the current state of the unit. It is used to select the operating mode, as well as the sub-features. For a detailed layout of the control panel functions, please see the "menu map" section on the following page.

## Menu Map

SELECTION	MODE DISPLAY	SELECTION	INSTRUCTION
Address	001		Set the DMX starting address
Reset	Yes		Reset
Inset	Auto Fast		Standalone-Fast: selection Standalone-Fast: mode display
	Auto Slow		Standalone-Slow: selection Standalone-Slow: mode display
	Sound		Standalone-Sound: selection Standalone-Sound: mode display
	Slave		Standalone-Slave: selection <u>Sets the fixture to respond to another fixture set to master</u>
		Standalone-Slave: mode display <u>Sets the fixture to respond to another fixture set to master</u>	
Reversal	Pan	Normal	Pan Norman Scan
		Reversal	Pan Reversal Scan
	Tilt	Normal	Tilt Norman Scan
		Reversal	Tilt Reversal Scan
Degree	Pan	540°	Pan 540°
		360°	Pan 360°
		180°	Pan 180°
	Tilt	270°	Tilt 270°
		180°	Tilt 180°
		90°	Tilt 90°
Channel	15 CH or 13 CH		Channel Personality (Advanced)
	10 CH		Channel Personality (Basic)
Load Data	Yes		Load Default

## DMX Operation

This is the operating mode which will allow for control with an external DMX controller. You must set the starting address for this mode. If this is your first time using DMX, then it is recommended that you refer to the "DMX Primer" section in the "Appendix" of this manual.

1. Press<MENU>,using<UP>and<DOWN>select until<ADRESS>appears on the LCD screen;
2. Press<ENTER>;
3. Using Value Button<UP>and Digit Button<DOWN>select DMX DATA<001—512>;
4. Press<ENTER>

## Standalone Operation

### Automatic Fast

This fixture has preprogrammed fast chases. These are accessed via the control panel. Please see the Instructions. Below for further explanation.

1. Press<MENU>,using<UP>and<DOWN>select until <INSET>appears on the LCD screen
2. Press<ENTER>
3. Select<AUTOFAT>
4. Press<ENTER>

### Automatic Slow

This fixture has preprogrammed slow chases. These are accessed via the control panel. Please see the Instructions. Below for further explanation.

1. Press<MENU>,using<UP>and<DOWN>select until <INSET>appears on the LCD screen
2. Press<ENTER>
3. Select<AUTOSLOW>
4. Press<ENTER>

### Sound-Active

This fixture has preprogrammed sound triggered chases. These are accessed via the control panel. Please see the Instructions. Below for further explanation.

1. Press<MENU>,using<UP>and<DOWN>select until <INSET>appears on the LCD screen
2. Press<ENTER>
3. Select<SOUND>
4. Press<ENTER>

### Channel

This fixture has preprogrammed channel triggered chases. These are accessed via the control panel. Please see the Instructions. Below for further explanation.

1. Press<MENU>,using<UP>and<DOWN>select until <CHANNEL>appears on the LCD screen
2. Press<ENTER>
3. Using<UP> and<DOWN>, Select<15CH> or <10CH> and <13CH> or <10CH>
4. Press<ENTER>

## Degree

This fixture has preprogrammed degree triggered chases. These are accessed via the control panel. Please see the Instructions. Below for further explanation.

1. Press<MENU>,using<UP>and<DOWN>select until <DEGREEL>appears on the LCD screen
2. Press<ENTER>
3. Using<UP> and<DOWN>, Select<PAN> or <TILT>
4. Press<ENTER>
5. Using<UP> and <DOWN>, Select degree,<PAN:540° ,360° ,180° > or<TILT: 270° , 180° ,90° >;
6. Press<ENTER>

## Reversal

This fixture has preprogrammed reversal triggered chases. These are accessed via the control panel. Please see the Instructions. Below for further explanation.

1. Press<MENU>,using<UP>and<DOWN>select until <Reversal>appears on the LCD screen
2. Press<ENTER>
3. Using<UP> and<DOWN>, Select<PAN> or <TILT>
4. Press<ENTER>  
Using<UP> and <DOWN>, Select degree,<PAN:normal, reversal> or<TILT: normal,reversal>
5. Press<ENTER>

## Reset

This fixture has preprogrammed reset triggered chases. These are accessed via the control panel. Please see the Instructions. Below for further explanation.

1. Press<MENU>,using<UP>and<DOWN>select until <Reset>appears on the LCD screen
2. Press<ENTER>
3. <YES>appears on the LCD screen;
4. Press<ENTER>

## Load Data

This fixture has preprogrammed load data triggered chases. These are accessed via the control panel. Please see the Instructions. Below for further explanation.

1. Press<MENU>,using<UP>and<DOWN>select until <LOAD DATA>appears on the LCD screen
2. Press<ENTER>
3. <YES>appears on the LCD screen;
4. Press<ENTER>

## Master/Slave

This is the operating mode which will allow one fixture to act as the “master” and control all of the other “slave” fixtures. You must set both the master and the slave(s) fixtures to the correct mode for this operation.

Please see the diagram below on the connections for your fixtures, as well as the setting to assign in the control panel.

It is not necessary to arrange the master fixture as the first fixture in the daisy chain. It may be any fixture in the daisy chain. For example: fixture 2, 5, 10 or 12, etc.

Only 1 fixture may be set to master.

Do not connect a DMX controller to the daisy chain for this operating mode.

In order to mirror one fixture to another, you may invert the pan and tilt on the mirrored fixture.

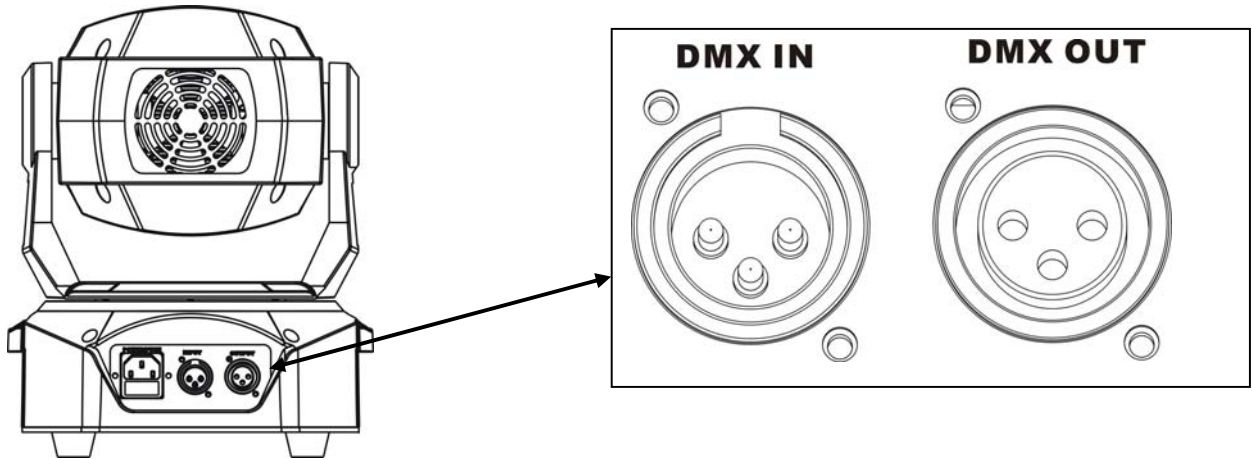

Set this fixture to master mode

Set this fixture to slave mode

Set this fixture to slave mode

Master

Slave

Slave

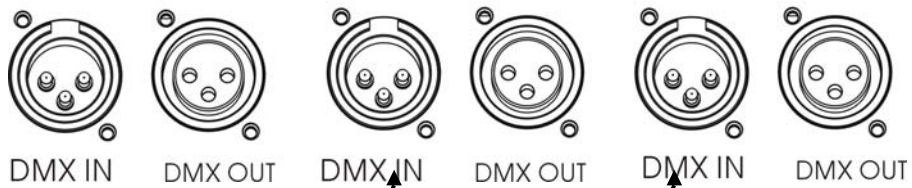

Additional signal  
(DMX) link out

# DMX Channel Values for 10 or 15-channel

## Advanced Mode(15-channel)

CHANNEL	VALUE	FUNCTION
1	000--255	Pan
2	000--255	Tilt
3	000--255	Pan Fine
4	000--255	Tilt Fine
5	000--255	X/Y Speed Fast~Slow
6	Color	
	000--015	White
	016--031	Color 1
	032--047	Color 2
	048--063	Color 2
	064--079	Color 4
	080--095	Color 5
	096--111	Color 6
	112--127	Color 7
	128--191	Rotating clockwise with rainbow effect
192--255	Rotating counter-clockwise with rainbow effect	
7	Gobo Wheel	
	000--018	White
	019--037	Gobo 1
	038--056	Gobo 2
	057--075	Gobo 3
	076--094	Gobo 4
	095--113	Gobo 5
	114--127	Gobo 6
	128--191	Rotating clockwise with increasing speed
	192--255	Rotating counter-clockwise with increasing speed
8	Gobo Rotation	
	000--009	NO Function
	010--116	Rotate clockwise (slow~fast)
	117--244	Rotate counter-clockwise (slow~fast)
	245--255	Gobo bounce
9	Fix Gobo	
	000--006	White
	007--013	Gobo 1
	014--020	Gobo 2
	021--027	Gobo 3
	028--034	Gobo 4
	035--041	Gobo 5
	042--048	Gobo 6
	049--055	Gobo 7
	056--062	Gobo 8
	063--069	Shake 8
	070--076	Shake 7
	077--083	Shake 6
	084--090	Shake 5
	091--097	Shake 4
	098--104	Shake 3
	105--111	Shake 2
	112--118	Shake 1
	119--125	White
	126--192	Rotating clockwise with increasing speed
193--255	Rotating counter-clockwise with increasing speed	
10	Strobe	
	000--008	No Function
	009--016	Open
	017--249	Strobe ( fast~slow)
	250--255	Open
11	Dimmer	
	000--255	Closed~Open
12	Function	
	000--044	No function
	045--064	Scan move-in-black
	065--234	No function
	235--244	Reset
245--255	No function	
13	000--255	Movement Macros
14	Prism	
	000--015	No function
	016--239	Prism rotate (slow~fast)
	240--255	Prism
15	000--255	Focus( Near~Far)

## Basic Mode(10-channel)

CHANNEL	VALUE	FUNCTION
1	000--255	Pan
2	000--255	Tilt
3	Color	
	000--015	White
	016--031	Color 1
	032--047	Color 2
	048--063	Color 2
	064--079	Color 4
	080--095	Color 5
	096--111	Color 6
	112--127	Color 7
	128--191	Rotating clockwise with rainbow effect
192--255	Rotating counter-clockwise with rainbow effect	
4	Gobo Wheel	
	000--018	White
	019--037	Gobo 1
	038--056	Gobo 2
	057--075	Gobo 3
	076--094	Gobo 4
	095--113	Gobo 5
	114--127	Gobo 6
	128--191	Rotating clockwise with increasing speed
	192--255	Rotating counter-clockwise with increasing speed
5	Gobo Rotation	
	000--009	NO Function
	010--116	Rotate clockwise (slow~fast)
	117--244	Rotate counter-clockwise (slow~fast)
	245--255	Gobo bounce
6	Fix Gobo	
	000--006	White
	007--013	Gobo 1
	014--020	Gobo 2
	021--027	Gobo 3
	028--034	Gobo 4
	035--041	Gobo 5
	042--048	Gobo 6
	049--055	Gobo 7
	056--062	Gobo 8
	063--069	Shake 8
	070--076	Shake 7
	077--083	Shake 6
	084--090	Shake 5
	091--097	Shake 4
	098--104	Shake 3
	105--111	Shake 2
	112--118	Shake 1
	119--125	White
	126--192	Rotating clockwise with increasing speed
193--255	Rotating counter-clockwise with increasing speed	
7	Strobe	
	000--008	No Function
	009--016	Open
	017--249	Strobe ( fast~slow)
	250--255	Open
8	Dimmer	
	000--255	Closed~Open
9	Prism	
	000--015	No function
	016--239	Prism rotate (slow~fast)
	240--255	Prism
10	000--255	Focus( Near~Far)



# DMX Channel Values for 10 or 13-channel

## Advanced Mode(13-channel)

## Basic Mode(10-channel)

CHANNEL	VALUE	FUNCTION
1	000--255	Pan
2	000--255	Tilt
3	000--255	Pan Fine
4	000--255	Tilt Fine
5	000--255	X/Y Speed Fast~Slow
6	Color	
	000--015	White
	016--031	Color 1
	032--047	Color 2
	048--063	Color 2
	064--079	Color 4
	080--095	Color 5
	096--111	Color 6
	112--127	Color 7
	128--191	Rotating clockwise with rainbow effect
192--255	Rotating counter-clockwise with rainbow effect	
7	Gobo Wheel	
	000--018	White
	019--037	Gobo 1
	038--056	Gobo 2
	057--075	Gobo 3
	076--094	Gobo 4
	095--113	Gobo 5
	114--127	Gobo 6
	128--191	Rotating clockwise with increasing speed
	192--255	Rotating counter-clockwise with increasing speed
8	Gobo Rotation	
	000--009	NO Function
	010--116	Rotate clockwise (slow~fast)
	117--244	Rotate counter-clockwise (slow~fast)
245--255	Gobo bounce	
9	Strobe	
	000--008	No Function
	009--016	Open
	017--249	Strobe ( fast~slow)
250--255	Open	
10	Dimmer	
	000--255	Closed~Open
11	Function	
	000--044	No function
	045--064	Scan move-in-black
	065--234	No function
	235--244	Reset
	245--255	No function
12	000--255	Movement Macros
13	000--255	Focus( Near~Far)

CHANNEL	VALUE	FUNCTION
1	000--255	Pan
2	000--255	Tilt
3	000--255	X/Y Speed Fast~Slow
4	Color	
	000--015	White
	016--031	Color 1
	032--047	Color 2
	048--063	Color 2
	064--079	Color 4
	080--095	Color 5
	096--111	Color 6
	112--127	Color 7
	128--191	Rotating clockwise with rainbow effect
192--255	Rotating counter-clockwise with rainbow effect	
5	Gobo Wheel	
	000--018	White
	019--037	Gobo 1
	038--056	Gobo 2
	057--075	Gobo 3
	076--094	Gobo 4
	095--113	Gobo 5
	114--127	Gobo 6
	128--191	Rotating clockwise with increasing speed
	192--255	Rotating counter-clockwise with increasing speed
6	Gobo Rotation	
	000--009	NO Function
	010--116	Rotate clockwise (slow~fast)
	117--244	Rotate counter-clockwise (slow~fast)
245--255	Gobo bounce	
7	Strobe	
	000--008	No Function
	009--016	Open
	017--249	Strobe ( fast~slow)
250--255	Open	
8	Dimmer	
	000--255	Closed~Open
9	Function	
	000--044	No function
	045--064	Scan move-in-black
	065--234	No function
	235--244	Reset
245--255	No function	
10	000--255	Focus( Near~Far)

# 5. APPENDIX

## DMX Primer

There are 512 channels in a DMX connection. Channels may be assigned in any manner. A fixture capable of receiving DMX will require one or a number of sequential channels. The user must assign a starting address on the fixture that indicates the first channel reserved in the controller. There are many different types of DMX controllable fixtures and they all may vary in the total number of channels required. Choosing a start address should be planned in advance. Channels should never overlap. If they do, this will result in erratic operation of the fixtures whose starting address is set incorrectly. You can however, control multiple fixtures of the same type using the same starting address as long as the intended result is that of unison movement or operation. In other words, the fixtures will be slaved together and all respond exactly the same.

DMX fixtures are designed to receive data through a serial Daisy Chain. A Daisy Chain connection is where the DATA OUT of one fixture connects to the DATA IN of the next fixture. The order in which the fixtures are connected is not important and has no effect on how a controller communicates to each fixture. Use an order that provides for the easiest and most direct cabling. Connect fixtures using shielded two conductor twisted pair cable with three pin XLR male to female connectors. The shield connection is pin 1, while pin 2 is Data Negative (S-) and pin 3 is Data positive (S+).

## General Maintenance

To maintain optimum performance and minimize wear, fixtures should be cleaned frequently. Usage and environment are contributing factors in determining frequency. As a general rule, fixtures should be cleaned at least twice a month. Dust build up reduces light output performance and can cause overheating. This can lead to reduced lamp life and increased mechanical wear. Be sure to power off fixture before conducting maintenance.

- Unplug fixture from power.
- Use a vacuum or air compressor and a soft brush to remove dust collected on external vents.
- Clean all glass when the fixture is cold with a mild solution of glass cleaner or Isopropyl Alcohol and a soft lint free cotton cloth or lens tissue.
- Apply solution to the cloth or tissue and drag dirt and grime to the outside of the lens.
- Gently polish optical surfaces until they are free of haze and lint.

The cleaning of external optical lenses and/or mirrors must be carried out periodically to optimize light output. Cleaning frequency depends on the environment in which the fixture operates. Damp, smoky or particularly dirty surroundings can cause greater accumulation of dirt on the unit's optics. Clean with soft cloth using normal glass cleaning fluid. Clean the external optics at least every 20 days. Clean the fixture at least every 30/60 days.



*Always dry the parts carefully after cleaning them.*



*Never spin a fan using compressed air.*

## Fixture Linking

You will need a serial data link to run light shows of one or more fixtures using a DMX controller or to run synchronized shows on two or more fixtures set to a master/slave operating mode. The combined number of channels required by all the fixtures on a serial data link determines the number of fixtures the data link can support.



**Fixtures on a serial data link must be daisy chained in one single line. To comply with the EIA-485 standard, no more than 32 fixtures should be connected on one data link. Connecting more than 32 fixtures on one serial data link without the use of a DMX optically-isolated splitter may result in deterioration of the digital DMX signal.**

*Maximum recommended serial data link distance: 500 m (1640 ft)  
Maximum recommended number of fixtures on a serial data link: 32*

## Data Cabling

To link fixtures together you must obtain data cables. You can purchase GLM certified DMX cables directly from a dealer/distributor or construct your own cable. If you choose to create your own cable please use data-grade cables that can carry a high quality signal and are less prone to electromagnetic interference.

### DMX Data Cable

Use a Belden© 9841 or equivalent cable which meets the specifications for EIA RS-485 applications. Standard microphone cables cannot transmit DMX data reliably over long distances. The cable must have the following characteristics:

Type:	shielded, 2-conductor twisted pair
Maximum capacitance between conductors:	30 pF/ft
Maximum capacitance between conductor and shield:	55 pF/ft
Maximum resistance:	20 ohms/1000 ft
Nominal impedance:	100 ~ 140 ohms

### Cable Connectors

Cabling must have a male XLR connector on one end and a female XLR connector on the other end.

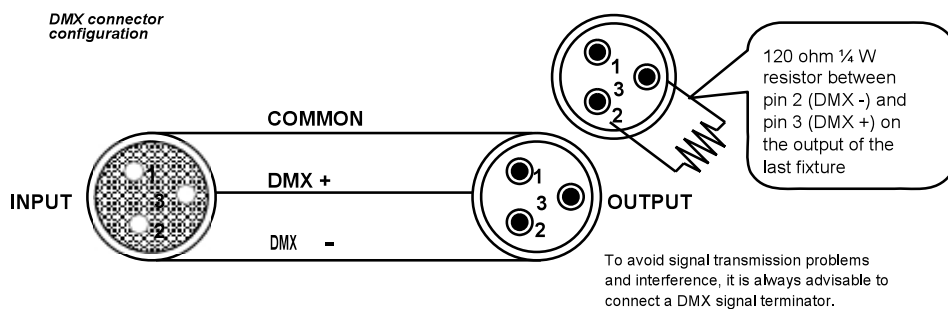

**Do not allow contact between the common and the fixture's chassis ground. Grounding the common can cause a ground loop, and your fixture may perform erratically. Test cables with an ohm meter to verify correct polarity and to make sure the pins are not grounded or shorted to the shield or each other.**

## 3-Pin to 5-Pin Conversion Chart



If you use a controller with a 5-pin DMX output connector, you will need to use a 5-pin to 3-pin adapter. The chart below details a proper cable conversion:

3-PIN TO 5-PIN CONVERSION CHART

Conductor	3-Pin Female (Output)	5-Pin Male (Input)
Ground/Shield	Pin 1	Pin 1
Data ( - ) signal	Pin 2	Pin 2
Data ( + ) signal	Pin 3	Pin 3
Not used		Pin 4
Not used		Pin 5

## Setting up a DMX Serial Data Link

1. Connect the (male) 3-pin connector side of the DMX cable to the output (female) 3-pin connector of the controller.
2. Connect the end of the cable coming from the controller which will have a (female) 3-pin connector to the input connector of the next fixture consisting of a (male) 3-pin connector.
3. Then, proceed to connect from the output as stated above to the input of the following fixture and so on.

Universal DMX Controller

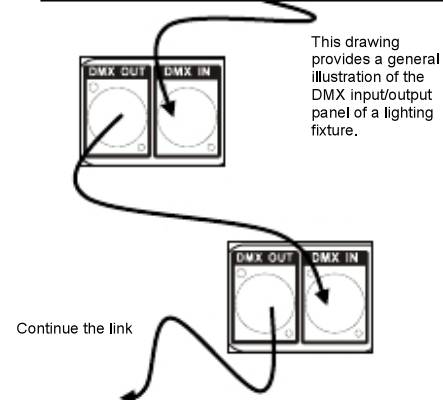
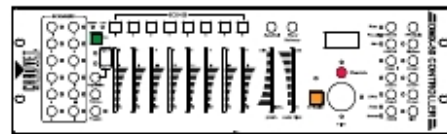

## Setting the Starting Address

This DMX mode enables the use of a universal DMX controller device. Each fixture requires a start address from 1~512. A fixture requiring one or more channels for control begins to read the data on the channel indicated by the start address. For example, a fixture that uses six DMX channels and was addressed to start on DMX channel 100, would read data from channels: 100, 101, 102, 103, 104, and 105. Choose start addresses so that the channels used do not overlap, and note the start address selected for future reference.

If this is your first time addressing a fixture using the DMX control protocol, we suggest jumping to the "Appendix" section and reading the heading "DMX Primer". It contains very useful information that will help you understand its use.

## General Troubleshooting

SYMPTOM	POSSIBLE CAUSE(S)	POSSIBLE ACTION(S)
Breaker/Fuse keeps blowing	<ul style="list-style-type: none"> <li>• Excessive circuit load</li> <li>• Short circuit along the power wires</li> </ul>	<ul style="list-style-type: none"> <li>• Check total load placed on the electrical circuit.</li> <li>• Check for a short in the electrical wiring (internal and/or external)</li> </ul>
Device does not power up	<ul style="list-style-type: none"> <li>• No power</li> <li>• Loose power cord</li> </ul>	<ul style="list-style-type: none"> <li>• Check for power on power outlet</li> <li>• Check power cord</li> </ul>
Fixture is not responding to DMX	<ul style="list-style-type: none"> <li>• Wrong DMX addressing</li> <li>• Damaged DMX cables</li> <li>• Wrong polarity settings on the controller</li> <li>• Loose DMX cables</li> <li>• Faulty DMX interface</li> <li>• Faulty Main PCB</li> </ul>	<ul style="list-style-type: none"> <li>• Check Control Panel and unit addressing</li> <li>• Check DMX cables</li> <li>• Check polarity switch settings on the controller</li> <li>• Check cable connections</li> <li>• Replace DMX input</li> <li>• Replace Main PCB</li> </ul>
Loss of signal	<ul style="list-style-type: none"> <li>• Non DMX cables</li> <li>• Bouncing signals</li> <li>• Long cable / Low level signal</li> <li>• Too many fixtures</li> <li>• Interference from AC wires</li> </ul>	<ul style="list-style-type: none"> <li>• Use only DMX compatible cables</li> <li>• Install terminator as suggested</li> <li>• Install amplifier right after fixture with strong signal</li> <li>• Install an optically coupled DMX splitter after unit #32</li> <li>• Keep DMX cables separated from power cables or black lights</li> </ul>

## Technical Specifications

### WEIGHT & DIMENSIONS

Length..... 250 mm  
Width..... 255 mm  
Height ..... 360 mm  
Weight.....6 kg

### POWER

Autoswitching Power Supply .....100~240 VAC, 50/60 Hz  
Power Consumption @ 120 VAC, 60 Hz .....148 W (0.1 A) max, 2 A inrush  
Power Consumption @ 230 VAC, 50 Hz .....144 W (0.5 A) max, 1 A inrush  
Power output .....4 units max  
Fuse..... F 3 A, 250 V

### LIGHT SOURCE

LED..... 1 (white) 30 W 2.2A, 50,000 hrs

### PHOTOPTIC

Luminance @ 1 m ..... 5300 lux  
Beam Angle ..... 14°

### GOBOS

Outside diameter ..... 23.8 mm  
Image diameter ..... 20 mm  
Maximum thickness..... 2 mm

### THERMAL

Maximum ambient temperature ..... 104° F (40° C)

### WARRANTY INFORMATION

Warranty .....1-year limited warranty