

# New 192 controller

# User manual



**Ver 1.0**

=====Catalogue=====

Technical specification-----	3
Cautions of safety-----	3
Installation of controller-----	3
Connecting scanner-----	4
DMX512 address distribution-----	4
Digit display instruction-----	5
1) running scene and manual operation display -----	5
2) edit scene operation display -----	5
3) edit and running cross chase operation display -----	5
Description rules-----	5
Rear instruction-----	6
Panel instruction-----	6
The number keys (1-12) in the scene / procedures / manual control mode of the corresponding menu -----	7
Description of <b>A</b> , <b>B</b> , <b>C</b> , <b>D</b> these four function keys in the Panel -----	7
<b>A</b> , <b>B</b> , <b>C</b> , <b>D</b> Four key scenes in the editing and editing, respectively, under the procedure menu -----	7
<b>A</b> , <b>B</b> , <b>C</b> , <b>D</b> Four key scenes in the editing process and editing of the functional state of operation-----	8
I)the schematic diagram of the edit scene panel -----	8
A) copy scene function-----	8
B) save scene function-----	9
C) delete scene function-----	9
II)edit chase state function operation-----	9
D) choose chase step and scene NO -----	9
E) delete chase step-----	9
F) delete chase -----	9
III)manual operation -----	9
A) delete manual operation -----	9
Edit scene -----	9
1) the schematic diagram of the edit scene panel -----	9
2) introduction of editing scene-----	10
edit chase -----	10
1) the schematic diagram of the edit cross chase panel -----	10
2) introduction of editing cross chase -----	10
running scene -----	11
1) the schematic diagram of the running scene panel -----	11
2) introduction of running scene -----	11
running chase-----	12
1) the schematic diagram of the running cross chase-----	12
2) ) introduction of running chase cross chase -----	12
manual operation-----	13
1) the schematic diagram of manual operation panel -----	13
2) ) introduction of manual operation-----	13

New 192, following the universal DMX 512 protocol, can control 12 16-channel scanners or other equipment, chase program and manual control of scanners can be performed at the same time. The functions are compact, it's convenient and flexible operation made it handled very easily. New 192 is suitable for different ballroom, taproom and small show.

### Technical specifications

Output signal	DMX512
DMX channels	1-192
Maximum control channel amount a scanner	16
Control amount of scanners	12
Amount of chase	12
Maximum chase steps in a chase	100
Amount of scanner scene	100
Running scene directly	12
Manual operation of scanner	Yes
Music run	Yes
Blackout function	Yes
Time of running chase can be adjust	Yes
Cross of running chase can be adjust	Yes
Display mode	LED digit display
Port of DMX output	XLR-D3F
Power supply	AC90-240V,50-60Hz,4W
Size	53.5*18.5*10CM
Weight	2.5KG

### Cautions of safety

- ◆ New 192 controller must be connected to the earthground to ensure the safety of user.
- ◆ When New 192 controller are working, don't plug in or plug out DMX 512 cable to avoid destroying the electronic components of the port in the controller.
- ◆ Don't splash any liquid to the controller to avoid destroying the electric components and the functions of the controller
- ◆ The scanner controller is precision electric equipment. please pay attention to moistureproof protection and dustproof. And please clean the controller panel timely.

### Installation of controller

Contents in the package of New 192 scanner controller:

- ◆ New 192 scanner controller: 1;
- ◆ Power supply line :1;
- ◆ User manual : 1.

Installing structure of New 192 scanner controller follows the international standard "19" 3U.it

can be embedded in operation board or directly installed in 19" shelf or cabinet.

The power of New 192 scanner controller has steady voltage output in so wide range of power supply voltage that it is adopt to the power supply of all the world .before the power supply is connected ,.Please check whether the voltage is in normal range of JMZ -002C

When the fuse needs to be replaced,please use the fuse with with the current capacity signed on the rear of the New 192.

### Connecting to scanner

According to DMX512 protocol , DMX signal cable must be screened twist cable with impedance of 120Ω. In practical engineering installation, if the whole length of the cable is short, the cable may be replaced by high quality screened two-core microphone cable.

User joins each end of the cable to a XLR plug. Foot 1 of the XLR plug is connected to the screen net of the cable. Twist lines (distinguished by different colors) are connected to foot 2 and 3. Foot 3 is signal + and foot 2 is signal -. Foot 2 and foot 3 of the plug cannot be confused.

To ensure correct DMX signal transmission, an 120Ω terminal matching resistance must be connected to the last equipment to absorb terminal signal reflection. The operation is as following: connect a 120Ω resistance to foot 2 and foot 3 of a plug then plug it to the output of the last scanner (or other equipment).

o

### Address distribution of DMX512

New 192 scanner controller utilizes channel 1-New 192 of DMX512 to transmit the control signals to various scanners. Each scanner is fixed with 16 control channels.

Scanner NO	First DMX address of scanner	
	Decimal code	Switch bit of scanner address
		123456789
1	1	10000000
2	17	10001000
3	33	10000100
4	49	10001100
5	65	10000010
6	81	10001010
7	97	10000110
8	113	10001110
9	129	10000001
10	145	10001001
11	161	10000101
12	177	10001101

## Digit display instruction

### 1) Running scene and manual operation display :

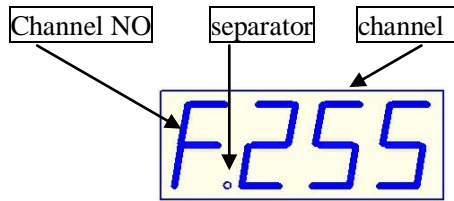

- 1) Channel NO——display the channel of current fader 0-f correspond 1-16 channel .
- 2) Channel ——display the current input channel value (range: 000-255)。
- 3) Separator ——used in distincting different content。

### 2) editing scene operation display :

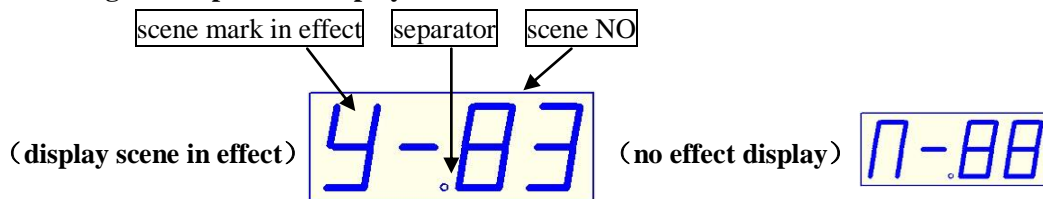

- 1) Scene mark in effect——the content of choosing the scene (Y means“ Yes”, N means“ NO”)。
- 2) scene NO——display the editing scene (range: 00-99)
- 3) Separator ——used in distincting different content。

### 3) edit and running cross chase operation display:

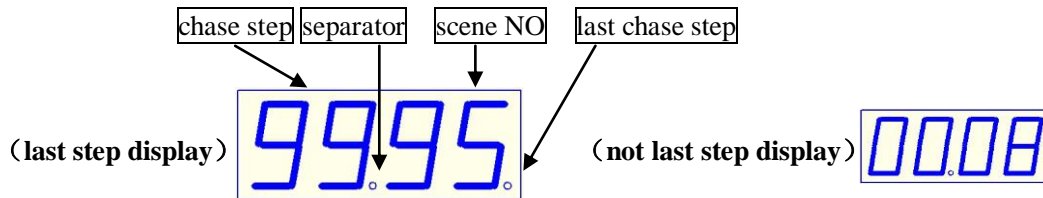

- 1) Chase step——the editing chase step NO, range: 00-99。
- 2) Scene NO——the scene will save in the chase step, range: 00-99。
- 3) Last chase step——the step is the last chase step。
- 4) Separator ——used in distincting different content。。
- 5) no chase display——no content in the chase (as follows)。

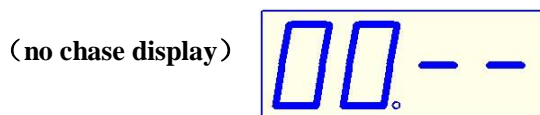

## Description rules

- 1) xxx mean key, switch or channel fader, for example: “Chase”。
- 2) ◀Step, Step▶, ◀Scene 和 Scene▶ keys in the following text , respectively, also referred to as A, B, C and D key,

Because the four buttons are regarded Composite function keys, They can also correspond to a state of expression of the corresponding functions。

3) in the Schematic diagram of the operation, Circle with the number of steps means a one-to-one relationship in explaining the steps and the schematic diagram of the serial number of the serial number for

Example : “①or “1)””; in “①and“1)” are Consistent, both mean first step or No. 1

### Rear instruction

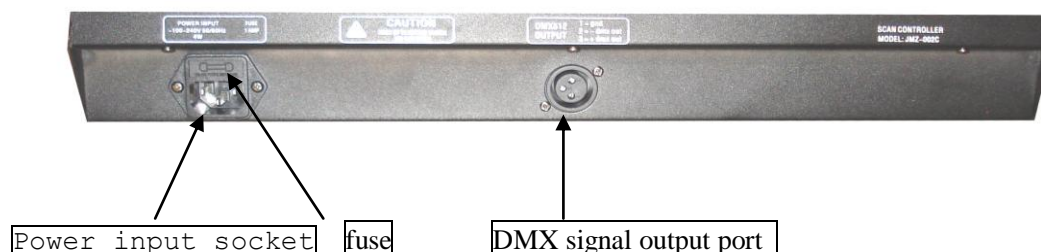

### Panel instruction

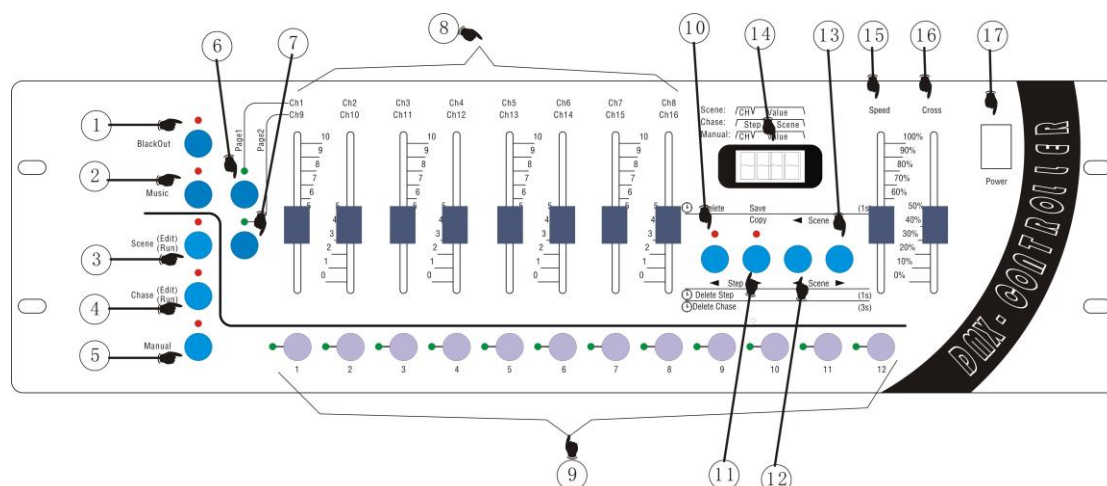

- 1) **BlackOut** Output black keys, pressing the button make light bright . when the control output value of Platform, all channels to 0, resulting in black scenes .
- 2) **Music** Voice-activated key , pressing the button make light bright, Running the program is triggered by the built-in microphone to run .
- 3) **Scene Edit / Run** Scene Editor / run key, if pressing time is more than 1 seconds, the indicator light flashes into the scene editor state; then if pressing for 1 second again will withdrawn from editing the state to the running state, Bright light is always on .
- 4) **Chase Edit / Run** walking light program editor / run key, if pressing time is more than 1 seconds, the indicator light flashes into the scene editor state; then if pressing for 1 second again will withdrawn from editing the state to the running state, Bright light is always on .
- 5) **Manual** Manual control key .
- 6) **Page1** Access keys page 1 .
- 7) **Page2** Access keys page 2 .
- 8) **Ch1/Ch9- Ch8/Ch16** Channel fader ( page one 1-8 / page two 9-16) .
- 9) **1-12** The number keys 1-12 (Used to select the No. field, and follow procedures and signal lights to choose) .
- 10) **◀Step** key is called as **A** key, (run)Operation to remove lantern; (edit scenes) deleted scenes;

(Edit the walking light procedure) Step Remove Programs / Remove Programs / decreasing step-by-step selection procedure.

- 11) **Step** key is called as **B** key, (Edit scenes) scene copy / preserve the scene; (Editor lights go procedure) incremental step-by-step selection procedure.
- 12) **Scene** key is called as **C** key, (Scene Editor / walking lights Procedure) its reduced choice key of scenes
- 13) **Scene** key is called as **D** key, (Scene Editor / walking lights Procedure) its increased choice key of scenes.
- 14) Digital display.
- 15) **Speed** Speed adjustment fader.
- 16) **Cross** Gradual adjustment fader.
- 17) **Power** Power switch.

### The number keys (1-12) in the scene / procedures / manual

#### control mode of the corresponding menu

function of number keys		the number keys 1-12
functional state		
<b>Scene Edit / Runk</b>	Editing Scene	Used to select the lamp
	Running scene	Used to select the running scenes
<b>Chase Edit / Run</b>	Editing program	Used to select the editing scenes
	Running program	Used to select the running scenes
<b>Manual</b>	Manual control	Used to select the lamp

#### Description of **A,B,C,D** these four function keys in the panel

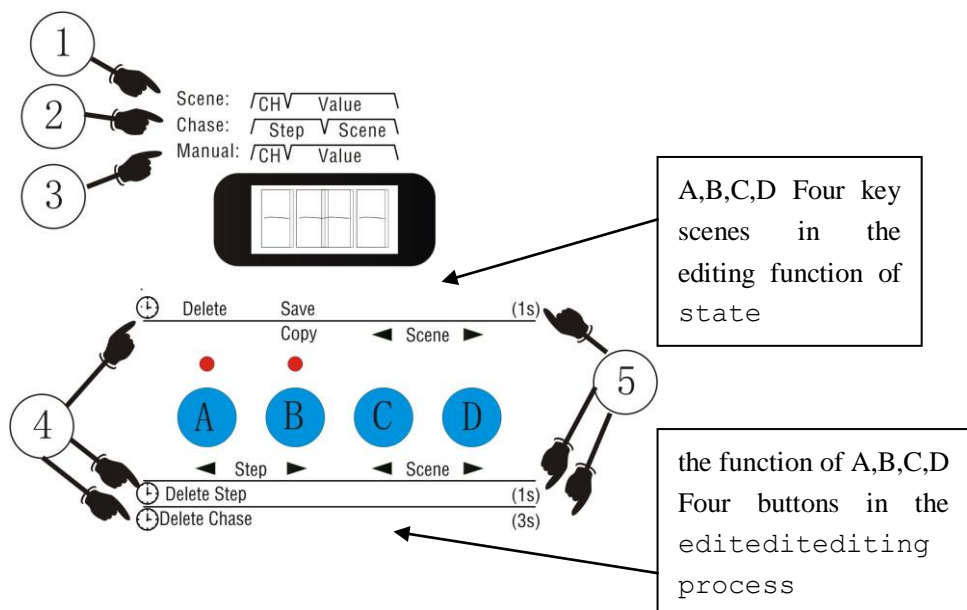

- ① **Step** When running scene with a digital display that's just - the first for a digital control channel number CH fader shows that the first 2-4 fader-bit digital control input values to show.
- ② When the lights go running process with a digital display that's just - the first-bit digital tube 1-2

run-time for the process step-by-step shows the current output, the first 2-4 bit digital control for step-by-step procedures to preserve the scene in the show its.

③ Manual control with digital display that's just - the first for a digital control channel number CH fader shows that the first 2-4 fader-bit digital control input values to show.

④ Delay icon button operation - said that the function of the corresponding button press and hold, through a period of time after the delay generated by.

⑤ Button to operate the time delay value - there is 1 second and 3 seconds .

**A, B, C, D four key scenes in the editing and editing, respectively,**

**under the procedure menu**

button function		A key	B key	C key	D key
		Edit scene	No delay	--	Copy Scene copy
Delay 1S	Delete delete scene		Save scene preservation	--	
Edit program	No delay	◀Step Step forward the election process	Step▶ Backward step-by-step selection procedure	◀Scene No. scenes to move the election	Edit program
	Delay 1S	Delete Step Delete the current step-by-step procedures	--	--	
	Delay 3S	Delete Chase Delete the current procedures	--	--	
Manual lantern	No delay	to clear the state of lantern	--	--	Manual lantern

**A, B, C, D four key scenes in the editing process and editing of the**

**functional state of operation**

I) Scenes in the editing function of the state of operation:

A) Scene copy function (Note: pressing time of less than 1 second):

- 1) Use C, D key to Select the scene to be copied (No. 3-4 bit digital tube will display the number of the scenes);
- 2) Press B key make the light bright;
- 3) use C, D key to choose to paste No. scenes, the scenes will be changed (No. 3-4 bit digital

- tube will display the number of the scenes);
- 4) press **B** key To make light out on the scene to complete the replication process, the latter scenario will be chosen before the contents of a scene instead of.
- B) Save the scene features (Note: pressing time is greater than 1 second):  
Press the B button for more than 1 second, the indicator light on the current editorial content is saved to the scene of the Taiwan-controlled memory.
- C) to remove scenes feature (Note: pressing time is greater than 1 second):  
Press the B button for more than 1 second, the indicator light on the current content has been edited to remove scenes.

II) in the editorial functions of the state of operation:

A) the selection process step-by-step with the scene number (Note: pressing time of less than 1 second):

1) A, B button for forward and backward step selection process, when the final step-by-step process occurs, then B button you can add a new procedure after the step-by-step.

2) C, D keys used to select the step number to preserve the scene.

B) Remove Programs Step (Note: press time more than 1 seconds, less than 3 seconds):

Press the A button for more than 1 second, the indicator light shows the current process step-by-step from the procedure was removed.

C) to remove the current procedure (Note: more than 3 seconds press time):

Press the A button for more than 3 seconds, indicator light will change the course of two shows that the current process is removed, this time 1-2 bit digital tube displays "00", the first-bit digital tube display 3-4 "--".

III) the functions of the state of manual steps:

A) Clear lantern status:

Running mode, press the A button used to clear the current output lantern.

## Edit scene

1) the schematic diagram of the edit scene panel:

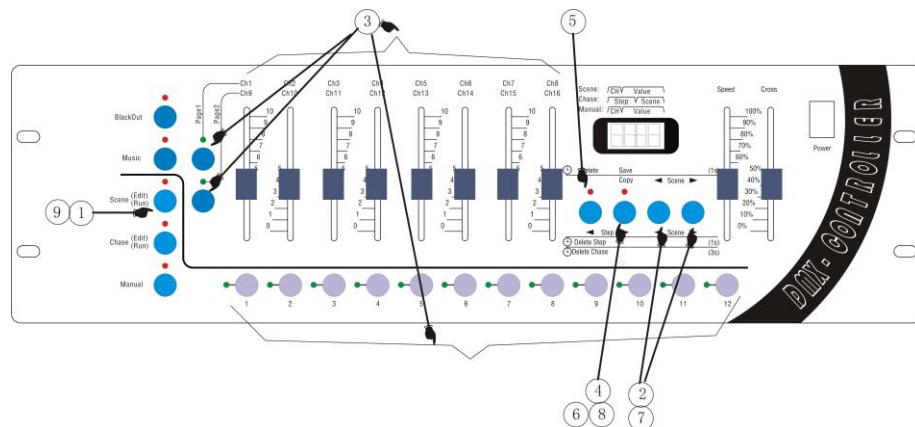

## The definition of the process steps of the edit SCEN:

- ① Press **SCENE** button in excess of 1 second, the indicator light glittering, enter the edit scene state.
- ② Use the **◀Scene&Scene▶** button to choose the scene serial number;
  - If want to edit the current scene, then run the step 3;
  - If want to delete the current scene, then run the step 5;
  - If want to copy the current scene, then run the step 7.
- ③ Edit the current scene: use the number button **1-12** to choose the light number, then with the cooperation of the **Page1 & Page2** button, use the handspike **Ch1/Ch9-Ch8/Ch16** to set the value of each channel;
- ④ Save the editing scene: press the **SAVE** button in excess of 1 second, when the panel indicator light and the screen glitter once, the current editing scene is saved;
  - If want to continue to edit other scene, run the step 2, choose another scene to edit; or run the step 9 to exit the editing scene state.
- ⑤ Delete the current scene: press the **DELETE** button in excess of 1 second, the lighting of the indicator light implies that the current scene is deleted.
  - If want to continue to edit other scene, run the step 2, choose another scene to edit; or run the step 9 to exit the editing scene state.
- ⑥ Copy the current scene: press the **COPY** button, until the indicator light lighting, enter the copy state, the contents of the current scene as the source of the scene content.
- ⑦ Use the **◀Scene&Scene▶** button to choose the scene serial number which is used to store the contents of the scene to copy, the serial number is the target serial number.
- ⑧ Press the **COPY** button again, the indicator go out, complete the copy process, then the contents of the source scene to cover the contents of the target scene.
  - If want to continue to edit other scene, run the step 2, choose another scene to edit; or run the step 9 to exit the editing scene state.
- ⑨ Exit the editing scene: press the **SCENE** button in excess of 1 second, the indicator light from glittering to lighting, system switch from editing scene state.

## Edit chase

### 1) the schematic diagram of the edit chase panel:

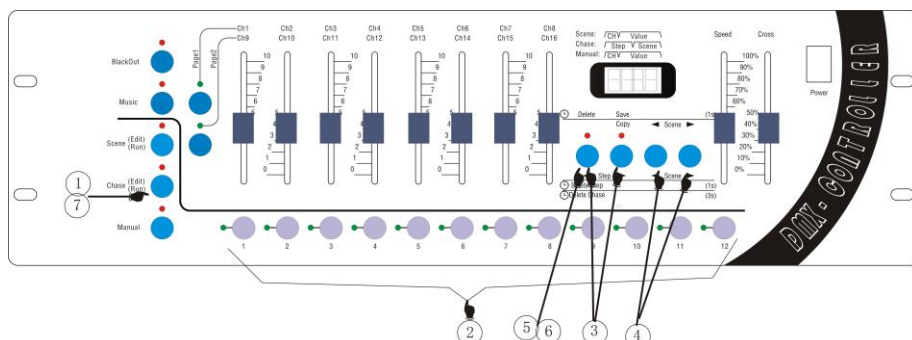

### 2) introduction of editing chase:

- ① press **Chase** over 1 second, and the indicator light will flash, meaning that the chase is in editing state (digit will display "CHA", prompting to select Chase number);

②selecting the number that you want: use Num Lock 1-12 to select the chase number (if the program is empty ,digit displays “00.--” . if step zero and the number of the saved scene in this step will be displayed ,such as “00,08”)

If you want to delete the current chase, execute the ⑤step

③select program step : channels ◀Step and ▶Step keys used to select the step of the Program that you want to edit

If you want to delete the current chase ,please execute the⑥ step

④selecting the scene number: using ◀Scene and ▶Scene, to select a scene number and the scene will be saved in the chase step selected in the ③ step.

If you want to editing othe steps of the current chase,execute the③ repeatedly;

⑤deleting current program: press Delete key over 3 seconds, and the indicator light will flash 2 times, then the current chase will be deleted. (digit will display”00.--”).

If you want to editing other steps of the current chase,execute the③ repeatedly;

⑥deleteing the current step of the chase: press Delete key over1second, and the pilot lamp will flash 1 time, then the current step will be deleted.

If you want to editing other steps of the current chase,execute the③ repeatedly;

⑦exiting the editing state of the chase of linear light: press Chase key over 1 second ,and the pilot will light constantly after flashing ,then the state will be switched to state of running chase of the linear light

## Running scene

### 1) the schematic diagram of the running scene panel:

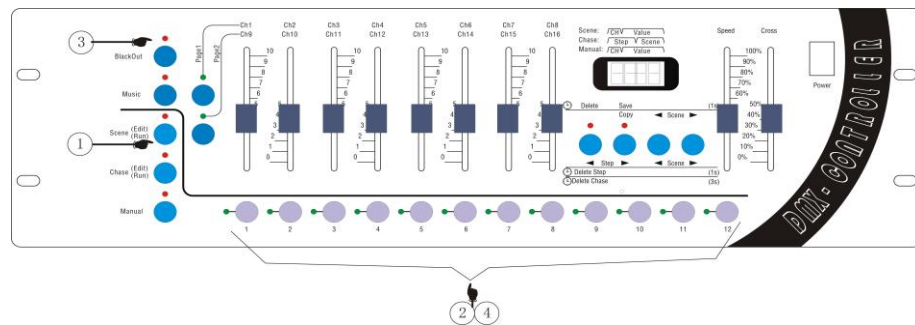

### 2) introduction of running scene's step

①press Scene key , and the lights are always on, meaning having entering the state of running scene

②selecting the scene number :use Num Lock 1-12 to choose the number you want

③if you want to output blackscene ,press blackout and if the indicator light is on ,the effect of black scene is being out ,or the effect is exited

④close the scene's output :use the NumLock to select the number of the scene that you want to close .

## Running chase

### 1) the schematic diagram of the running chase panel:

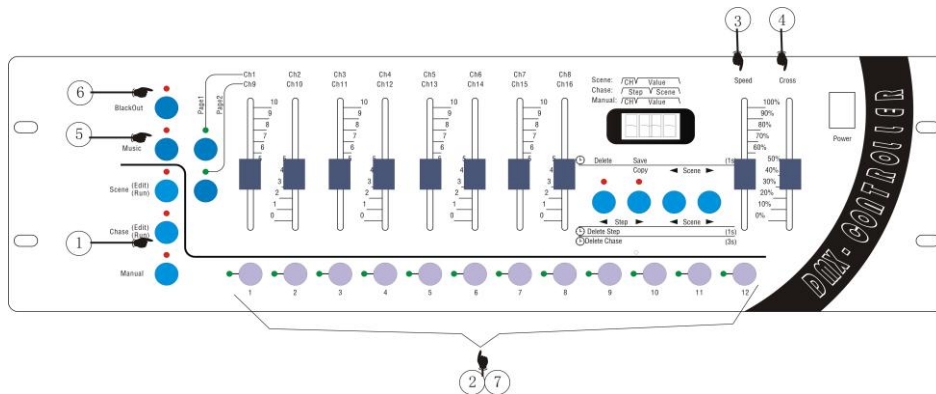

### 2) introduction of running the chase

- ① press **Chase** to light the indicator light
- ② select the chase number you want: use Num Lock 1-12 to select the number
- ③ adjusting the settling-time :adjust the clipper **Speed** to adjust the setting-time of the chase steps .The top means the shortest time and the bottom the longest
- ④ adjusting the shading-time :adjust the clipper **Cross** to adjust the shading-time of the chase step, and .The top means non-shading and the more declined the longer shading-time
- ⑤ running by sound-activated: if you need to activate chase in the way of sound-activated ,press **Music** to make the lamp on, meaning having entered the state of sound-activated, and if the lamp is off ,it means the sound-activated state is exited
- ⑥ Outputting blackscene: if you need to output blackscene ,press **Blackout** key so that you can choose to whether output blackscene or not
- ⑦ exiting the running chase: use NumLock 1-12 to select the running chase number and the chase will be closed.

## manual operation

### 1) the schematic diagram of the manual operation panel:

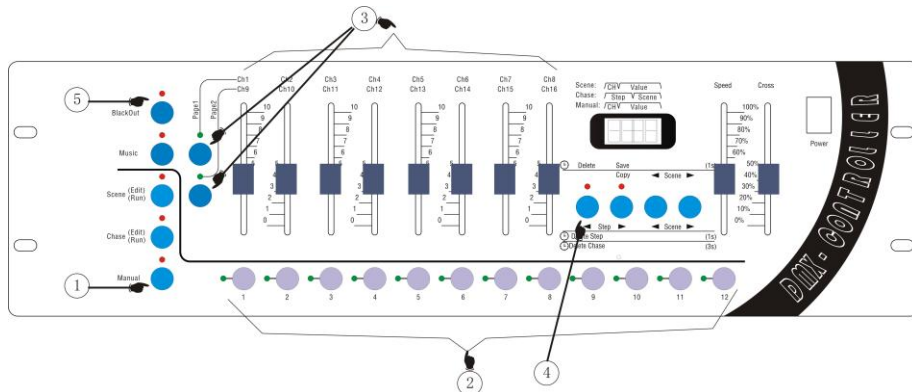

### 2) The definition of the process steps of the manual operation :

- ① Entering the manual state: press the **MANUAL** button, make the indicator light constantly shining, enter manual operation state.
- ② Choosing the manual lights: use the number button **1-12** to choose the number of lights.
- ③ Modify the value of the channel of the lights: with the cooperation of the **Page1** & **Page2** button and the channel handspike can realize the purpose of manual control of the lights. Press **Page1** button, the indicator light on, handspike correspond to **Ch1-Ch8**; press **Page2** button, the indicator light on, handspike correspond to **Ch9-Ch16**, realize the switch operation of the 16 channels.
- ④ Cleanout the manual state: press **DELETE** button, cleanout the output state which was set on the manual state.
- ⑤ If need the effects of blackout, press **BLACKOUT** button, switch the output